

<b>L05011i2</b>	LED Driver 20W,	6 - 42 Vdc,	100 – 1200 mA	<b>L1W1MID120D-20E</b>
<b>L05011i3</b>	LED Driver 20/24W,	6 - 42 Vdc,	200 – 1200 mA	<b>L1M1MID120S-24E</b>
<b>L05011i4</b>	LED Driver 20/24W,	6 - 42 Vdc,	200 – 1200 mA	<b>L1P1MID120S-24E</b>

## Engineered for Best Fixture Performance

Fulham LumoSeries drivers are all built on core engineering design principles for exceptional standards of performance and reliability in LED systems. Highest-grade critical components together with design features for thermal management ensure excellent reliability. Our low ripple designs create flicker-free lighting and perfectly smooth dimming. Simplicity of specification and installation is a key characteristic of all Fulham LumoSeries drivers. Hence the wide voltage and current ranges and industry leading low inrush current.



Suitable for:



**Future proof LED driver with industry leading voltage and current range enabling seamless support of LED generations.**

## Engineered for Performance

- Industry leading efficiency
- Excellent EMC behavior
- Very high power factor
- Hot swapping of LEDs > 3W

## Engineered for Reliability

- Low inrush current
- Thermal protection (automatic current limiter)
- Short and open circuit protection, overload and overvoltage protection

## Engineered for Simplicity.

- Future-proof flexibility – industry leading voltage and current range enabling seamless support of LED generations and minimizing supply chain complexity

## 5 year warranty

Fulham LumoSeries takes pride in the quality of its products. We not only develop all products in house, they are also produced to ensure guaranteed reliability and performance. Fulham LumoSeries drivers come with the assurance of a 5 year warranty. After all, with typical LED lifetimes of 50,000 hours, it is critical to have a power supply with equal reliability.



## Product features

- Wide output voltage range 6 - 42 Vdc
- Wide range of current settings 100 - 1200 mA
- 0-10V-, 1-10V-, potentiometer- and pulse dimming
- Suitable for warm dimming (natural toning/ dim-to-warm) LEDs
- Max inrush current 327 mA
- Zero ripple current
- Dual stage topology
- Active overcurrent protection
- Up to 85 % efficiency across a wide range of loads
- Power factor 0.97
- SELV
- ENEC certified
- Engineered and Manufactured in Europe

## Certificates and standards

- ENEC05, CE
- EN55015 / EN61000-3-2 / EN61347-2-13 / EN61347-1 / EN61547 / EN62384 / SELV

## Classifications



## Specific technical data

Type	Efficiency at full load	Output current	Constant voltage output	Output voltage range	Open circuit output voltage	Max. output power	Dimming
L05011i2	85 %	100 - 1200 mA	6 - 42 Vdc	6 - 42 Vdc	48 Vdc	20 W	0-10V, 1-10V, potentiometer 100K log b, pulse (SELV)
L05011i3	85 %	200 - 1200 mA (20W) 600 - 900 mA (24W)	-	6 - 42 Vdc	48 Vdc	20 W 24 W	0-10V, 1-10V, potentiometer 100K log b (SELV)
L05011i4	85 %	200 - 1200 mA (20W) 600 - 900 mA (24W)	-	6 - 42 Vdc	48 Vdc	20 W 24 W	pulse (SELV)

## Technical data

Rated supply voltage	220-240 Vac
Input voltage	180-240 Vac / 150-275 Vdc*
Mains frequency	50/60 Hz
Output current tolerance	5 %
100 Hz ripple current at full load	<1 %
Power factor at full load	0.97
Standby power	350 mW
Nominal line current at 240 Vac	110 mA
Dimming method	linear
Minimum dim level	15 mA - off
Non-volatile memory	Yes
Startup time	< 1s
Warm up time to 95% of light output	< 2s
Output isolation	SELV
Surge protection (diff. / comm.)	2 kV / 6 kV
IP classification	IP 20
Circuit lifetime	50,000 hrs at Tc max.
Case dimensions	110 x 52 x 23.5 mm
Case material	Polyamide 6 (PA6)

\* External DC fuse required

## Dimensions

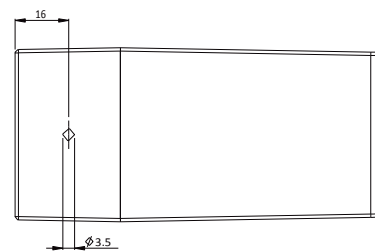
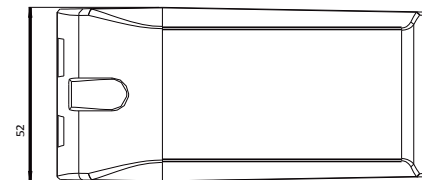
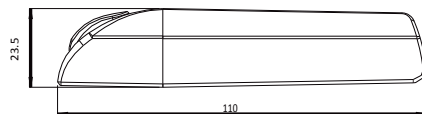

## Inrush current

Mains max. peak inrush at full load	0.200A per driver on phase 60° (average starting angle)*
	0.327A per driver on phase 90° (worst case starting angle)*
	0.162A per driver on phase 60° (average starting angle)**
	0.170A per driver on phase 90° (worst case starting angle)**

\*\* Tested at 240 Vac 1 driver connected, with TTI HA1600A analyzer.

\* Tested at 240 Vac 10 drivers parallel connected, with TTI HA1600A analyzer.

## Maximum number of drivers on automatic circuit breakers

Automatic circuit breaker type	C10	C13	C16	C20	B10	B13	B16	B20
L05011i2 / L05011i3 / L05011i4	85	110	136	170	85	110	136	170

## Thermal specifications

Ambient temperature range (Ta)	L05011i2: -20° to 42°C* L05011i3,4: -20° to 42°C*
Maximum case temperature (Tc)	L05011i2: <80°C** L05011i3,4: < 70°C ***
Storage temperature range	-20 to 50°C

\* -20° to 50°C when mounted on a heat conductive surface

\*\* 85°C when mounted on a heat conductive surface at Ta 50°C max.

\*\*\* 83°C when mounted on a heat conductive surface at Ta 50°C max.

### Overload protection

If the maximum output power is exceeded, the LED driver reduces the LED output current. After elimination of the overload the nominal operation is restored automatically.

### Over temperature protection

The LED driver is protected against thermal overload. If the temperature limit is exceeded, the output current is reduced.

### Active overcurrent protection

Active overcurrent protection to allow hot swapping of LEDs higher than 3 Watt.

### Unexpected behavior when using 0-10V/1-10V

When controlling the driver with a 0-10V / 1-10V system it can occur that the 0-10V / 1-10V controller delivers (or allows) a voltage that is higher than 12V. The voltage triggers the driver in to 'pulse switch mode'. This will result in unexpected and unintended behavior of the LED's. In case of symptoms like these, it is sufficient to clamp the output of the control system with a 10 or 12V zener diode. (cathode to the positive). To prevent this from happening always use a system / dimmer which complies with EN60929 Annex E.

### Short-circuit protection

In case of a short circuit the LED driver switches to protection mode. After the removal of the short-circuit the LED driver will recover automatically.

### No-load operation

In no-load operation the output voltage will not exceed the specified open circuit output voltage.

### Secondary switching

The L05011i2, -i3 and i4 are designed to switch the LEDs on/off by using the dim input or by switching the mains. The L05011i2, -i3 and -i4 are not designed to switch the LEDs directly on/off in the secondary power line.

### LED load

Fulham LumoSeries LED drivers are designed to drive passive LEDs, - COB's and -LED assemblies  
Proper function is not guaranteed when (LED)loads with active components are used.

## Wiring diagram

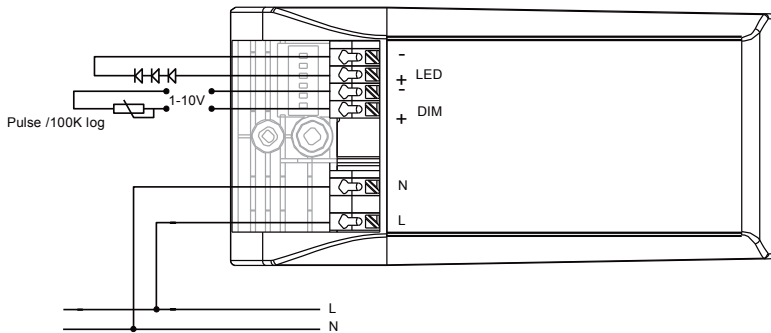

### Wiring of device

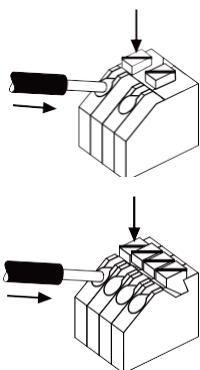

#### Solid

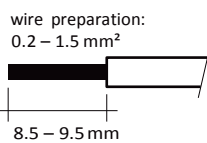

#### Stranded

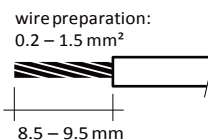
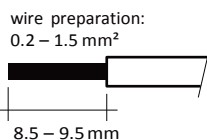
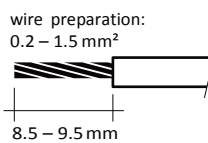

### Strain relief

The strain relief inserts can be removed to accommodate wiring of larger diameters.

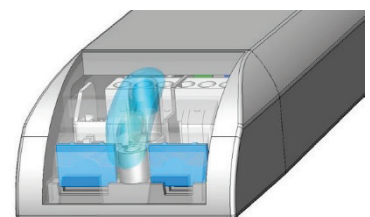

## Dimming

The L05011i2, -i3 and -i4 can be switched on/off and dimmed by using the dim input. Only class II dimmers may be used.

### Pulse dimming

The L05011i2 and -i4 can be dimmed with a pulse-switch.

In case of multiple drivers on one dimmer make sure that the wires are connected according to polarity.

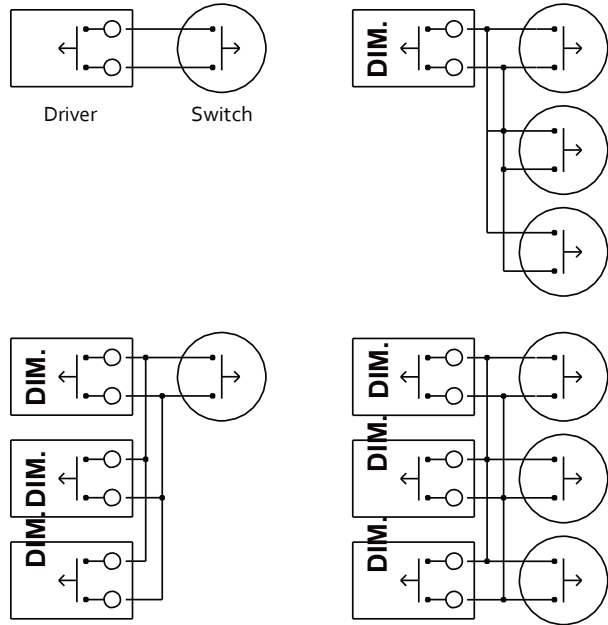

### 1-10 V dimming

The L05011i2, and i3 can be dimmed with 0-10V, 1-10V or a potentiometer. In case of multiple drivers on one dimmer make sure that the wires are connected according to polarity.

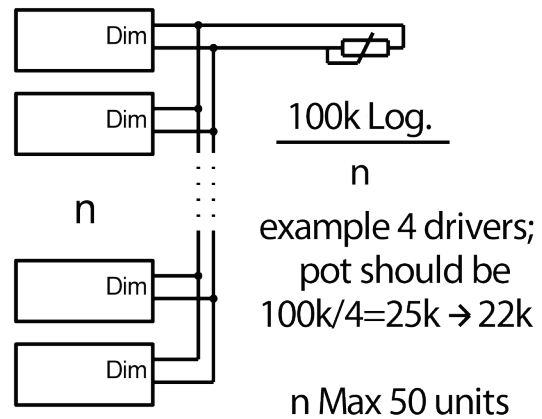

### Warm dimming

The L05011i2/i3 and i4 use the linear dimming method instead of PWM. Therefore the driver is suitable for warm dimming / dim-to-warm / natural toning / sunset dimming / warm glow dimming.

**Dipswitch setting**

The constant current or constant voltage setting can be adjusted by using the dipswitch terminal on the driver. In these tables all the supported currents and voltages are listed down.

When the switch lever is in the up position (ON), it is seen as a '1'.  
When the switch lever is in the down position (Off), it is seen as a '0'.

The examples below demonstrate two settings for the L05011i2.

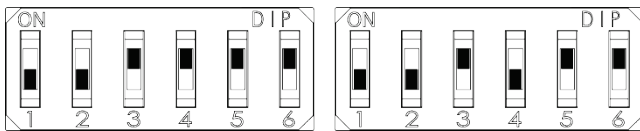

1050mA 1-10V dim

700mA 1-10V dim

**L05011i2 settings**

Output current (mA)	Dim mode	Setting					Current / voltage mode	Maximum Output Voltage / Current
		1	2	3	4	5		
100 mA	X	0	0	0	0	1	42.0 V	
120 mA	X	1	0	0	0	1	42.0 V	
150 mA	X	0	1	0	0	1	42.0 V	
240 mA	X	1	1	0	0	1	42.0 V	
350 mA	X	0	0	1	0	1	42.0 V	
360 mA	X	1	0	1	0	1	42.0 V	
480 mA	X	0	1	1	0	1	41.7 V	
500 mA	X	1	1	1	0	1	40.0 V	
550 mA	X	0	0	0	1	1	36.3 V	
650 mA	X	1	0	0	1	1	30.7 V	
700 mA	X	0	1	0	1	1	28.6 V	
720 mA	X	1	1	0	1	1	27.8 V	
900 mA	X	0	0	1	1	1	22.2 V	
1000 mA	X	1	0	1	1	1	20.0 V	
1050 mA	X	0	1	1	1	1	19.0 V	
1200 mA	X	1	1	1	1	1	16.7 V	
reserved	X	1	0	0	0	0		
6 V	X	0	1	0	0	0	1200 mA	
8 V	X	1	1	0	0	0	1200 mA	
10 V	X	0	0	1	0	0	1200 mA	
12 V	X	1	0	1	0	0	1200 mA	
18 V	X	0	1	1	0	0	1100 mA	
19 V	X	1	1	1	0	0	1050 mA	
24 V	X	0	0	0	1	0	833 mA	
28 V	X	1	0	0	1	0	714 mA	
30 V	X	0	1	0	1	0	667 mA	
32 V	X	1	1	0	1	0	625 mA	
36 V	X	0	0	1	1	0	556 mA	
38 V	X	1	0	1	1	0	526 mA	
40 V	X	0	1	1	1	0	500 mA	
42 V	X	1	1	1	1	0	476 mA	
Pulse dim	1	X	X	X	X	X		
1-10 Vdim	0	X	X	X	X	X		

Output current (mA)	Dipswitch no						U Max (V)
	1	2	3	4	5	6	
200 mA	0	1	0	0	0	0	42.0
220 mA	1	1	0	0	0	0	42.0
240 mA	0	0	1	0	0	0	42.0
260 mA	1	0	1	0	0	0	42.0
280 mA	0	1	1	0	0	0	42.0
300 mA	1	1	1	0	0	0	42.0
320 mA	0	0	0	1	0	0	42.0
340 mA	1	0	0	1	0	0	42.0
360 mA	0	1	0	1	0	0	42.0
380 mA	1	1	0	1	0	0	42.0
400 mA	0	0	1	1	0	0	42.0
420 mA	1	0	1	1	0	0	42.0
440 mA	0	1	1	1	0	0	42.0
460 mA	1	1	1	1	0	0	42.0
480 mA	0	0	0	0	1	0	41.7
500 mA	1	0	0	0	1	0	40.0
520 mA	0	1	0	0	1	0	38.5
540 mA	1	1	0	0	1	0	37.0
560 mA	0	0	1	0	1	0	35.7
580 mA	1	0	1	0	1	0	34.5
600 mA	0	1	1	0	1	0	33.3
620 mA	1	1	1	0	1	0	32.3
640 mA	0	0	0	1	1	0	31.3
660 mA	1	0	0	1	1	0	30.3
680 mA	0	1	0	1	1	0	29.4
700 mA	1	1	0	1	1	0	28.6
720 mA	0	0	1	1	1	0	27.8
740 mA	1	0	1	1	1	0	27.0
760 mA	0	1	1	1	1	0	26.3
780 mA	1	1	1	1	1	0	25.6
800 mA	0	0	0	0	0	1	25.0
820 mA	1	0	0	0	0	1	24.4
840 mA	0	1	0	0	0	1	23.8
860 mA	1	1	0	0	0	1	23.3
880 mA	0	0	1	0	0	1	22.7
900 mA	1	0	1	0	0	1	22.2
920 mA	0	1	1	0	0	1	21.7
940 mA	1	1	1	0	0	1	21.3
960 mA	0	0	0	1	0	1	20.8
980 mA	1	0	0	1	0	1	20.4
1000 mA	0	1	0	1	0	1	20.0
1020 mA	1	1	0	1	0	1	19.6
1040 mA	0	0	1	1	0	1	19.2
1060 mA	1	0	1	1	0	1	18.9
1080 mA	0	1	1	1	0	1	18.5
1100 mA	1	1	1	1	0	1	18.2
1120 mA	0	0	0	0	1	1	17.9
1140 mA	1	0	0	0	1	1	17.5
1160 mA	0	1	0	0	1	1	17.2
1180 mA	1	1	0	0	1	1	16.9
1200 mA	0	0	1	0	1	1	16.7
600 mA (24W)	1	0	1	0	1	1	40.0
650 mA (24W)	0	1	1	0	1	1	36.9
700 mA (24W)	1	1	1	0	1	1	34.3
750 mA (24W)	0	0	0	1	1	1	32.0
800 mA (24W)	1	0	0	1	1	1	30.0
850 mA (24W)	0	1	0	1	1	1	28.2
900 mA (24W)	1	1	0	1	1	1	26.7
350 mA	0	0	1	1	1	1	42.0
500 mA	1	0	1	1	1	1	40.0
700 mA	0	1	1	1	1	1	26.7
1050 mA	1	1	1	1	1	1	19.1

**Power factor L05011i2**

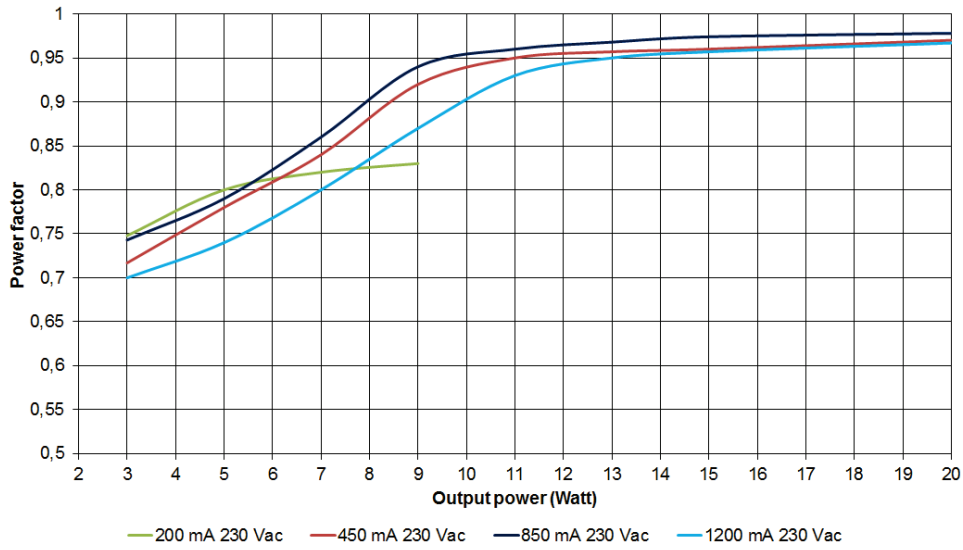

**Efficiency L05011i2**

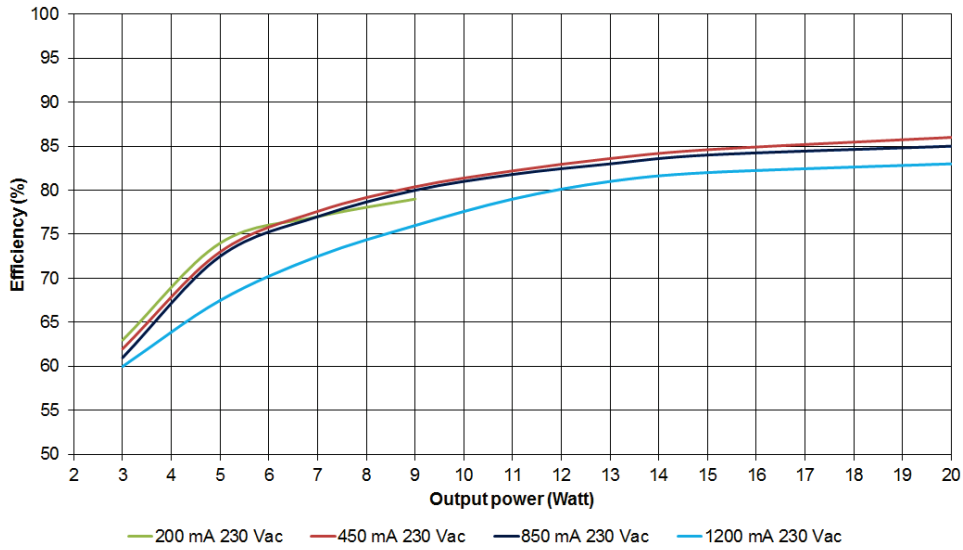

**Power factor L05011i3 / L05011i4**

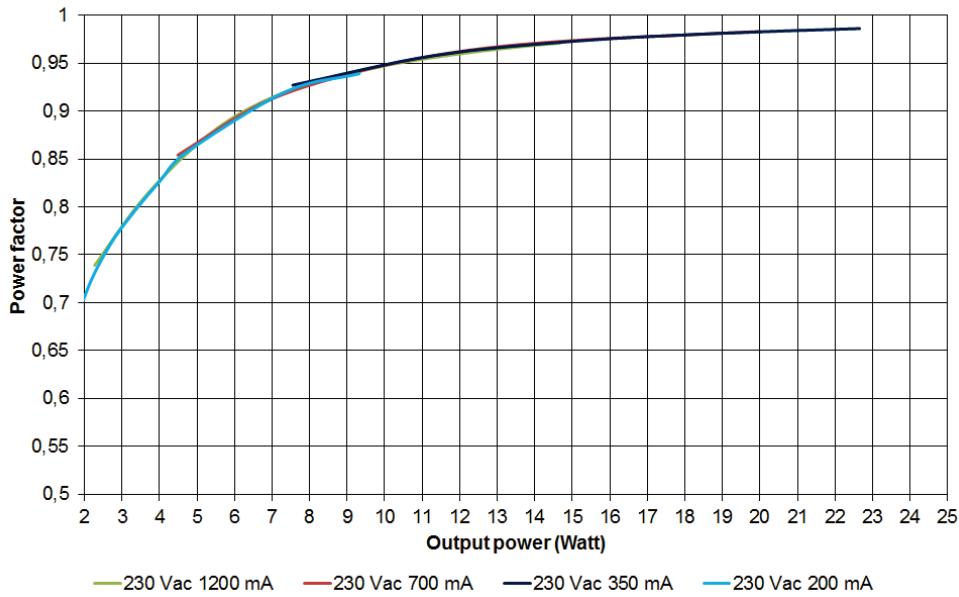

**Efficiency L05011i3 / L05011i4**

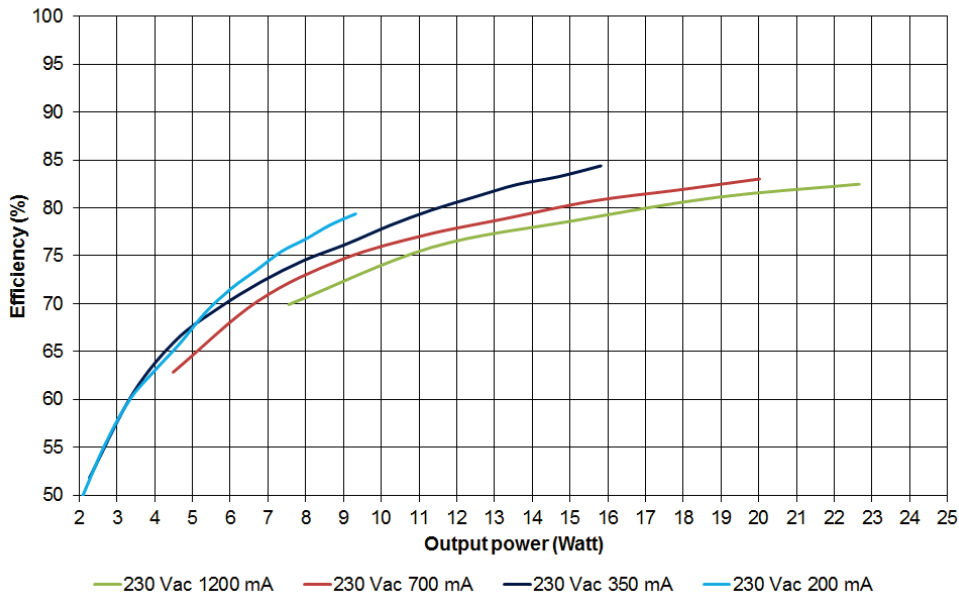

---

Part	Part number	Alternate Part	Packaging carton	Multibox carton	Weight per piece
<b>L05011i2 LED Driver 20W, 6 - 42 Vdc, 100 - 1200 mA, uni dim</b>	L05011i2	L1W1MID120D-20E	20 pieces	240 pieces	100 g
<b>L05011i3 LED Driver 20/24W, 6 - 42 Vdc, 200 - 1200 mA, 1-10V / potentiometer</b>	L05011i3	L1M1MID120S-24E	20 pieces	240 pieces	100 g
<b>L05011i4 LED Driver 20/24W, 6 - 42 Vdc, 200 - 1200 mA, puls dim</b>	L05011i4	L1P1MID120S-24E	20 pieces	240 pieces	100 g

---

Berenkoog 56  
NL-1822 BZ Alkmaar  
The Netherlands

[www.Fulham.com](http://www.Fulham.com)

© 2017, Fulham Company. All rights reserved. Designs and specifications may change without prior notice. Fulham products are not designed, intended, or authorized for any application in which the failure of the product could cause personal injury.